

On load-bearing floors with Slotted Board EPS 16

Design

Under Floor Heating using Slotted Board EPS 16 is for laying on load-bearing floors only; giving exceptionally low construction height. The system is made up of 16 mm thick slotted insulation boards, with an aluminium heat distribution plate, 0.5 mm thick and factory fixed. The heat distribution plate covers the entire surface of the insulation board. The slotted board, turning board and feeding board are made of high density EPS and provides extremely high resistance to short and long term compression.

Requirements

We recommend the use of “weather compensation” control of flow temperature for optimum efficiency and that manifolds are balanced in line with our design data. The settings should be recorded for future reference.

The plates must be laid load bearing floors only. Suitable floor structures are solid floors or suspended floors of minimum 22 mm floor grade chipboard fixed to joists spaced at a maximum of 600 mm. Where ceramic tiles are to be used over suspended floors cross batten at 300. The system can be installed as floating or fixed structure; the choice depends on the kind of floor finish to be used (see section entitled “Top layer”).

We recommend referencing local or international building regulations where relevant and trade organisations specialising in flooring materials (e.g. in UK, TRADA for wood floors).

Construction outline

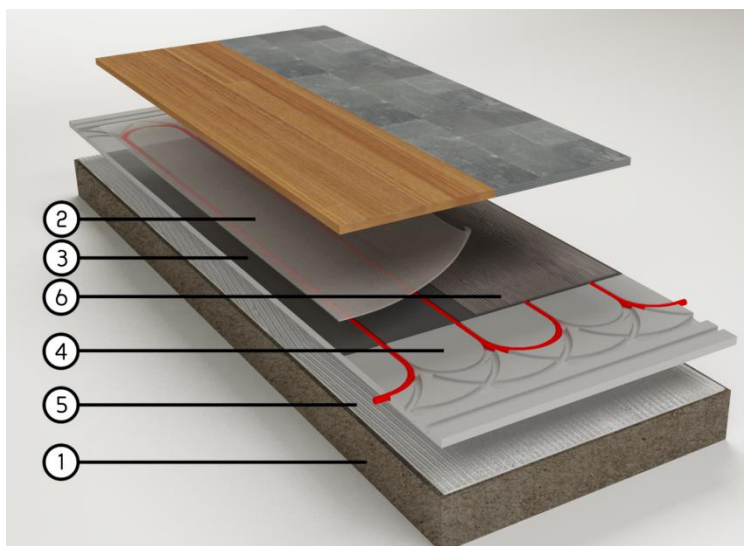

Slotted Board EPS 16

1. Load-bearing floor construction

2. **Vapour barrier**, when installed "floating"

3. Slotted Board EPS 16

Dimensions 1200 x 600 x 16 mm with four slots, c/c 150 mm, suitable for Under Floor Heating Pipe PE-Xa 12. The aluminium heat distribution plate is factory fixed.

4. Turning Board EPS 16

Dimensions 600 x 300 x 16 mm

5. **Glue**. (Can be floated with vapour barrier if final floor finish is unbonded).

6. Adhesive

Adhesives layer between insulation board and sub-floor, and between aluminium plates and ceramic tiling.

Surface layer

(For detailed information on this topic, see the section entitled “Installing the final floor finish”.)

Parquet or laminate floor

The heating plates are laid out “floating” over a PE vapour barrier, then open-cell foam sheet, over which, is laid the final wood floor. Surface layer must be at least 9 mm thick.

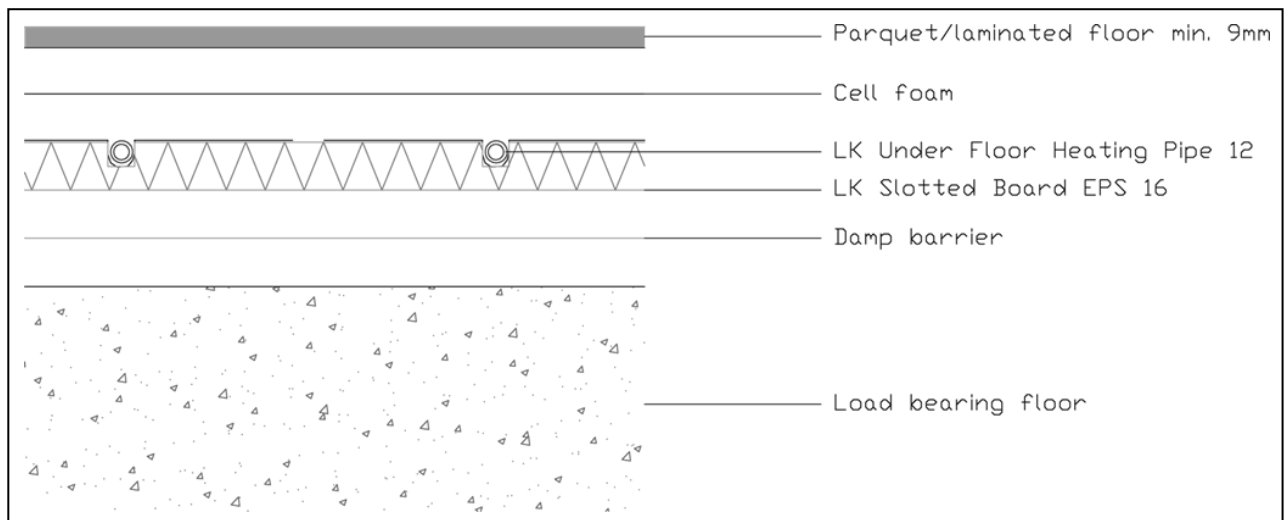

EPS 16 laid out “floating” on load bearing floor. Surface layer parquet.

Plastic or linoleum carpets

Dry areas

The heating plates are laid out “floating” over a PE vapour barrier. Soft floor finishes require an additional sub-floor. Lay cellfoam over the heating plates then lay 12 mm (minimum) chipboard over the cellfoam.

Wet areas and an alternative solution for dry areas

The heating plates are glued to the sub-floor. Levelling compound (filler) is applied to form a drainage slope (minimum 12 mm thick adjacent to a floor drain). Vinyl flooring is then laid over the floor.

Ceramic tiling or natural stone

Dry areas

The floor-based heating plates are glued to suitable strengthened sub-floor. Ceramic tiling/natural stone is fixed (adhesive) direct over the heating panels. Smallest approved tile size 10x10 cm.

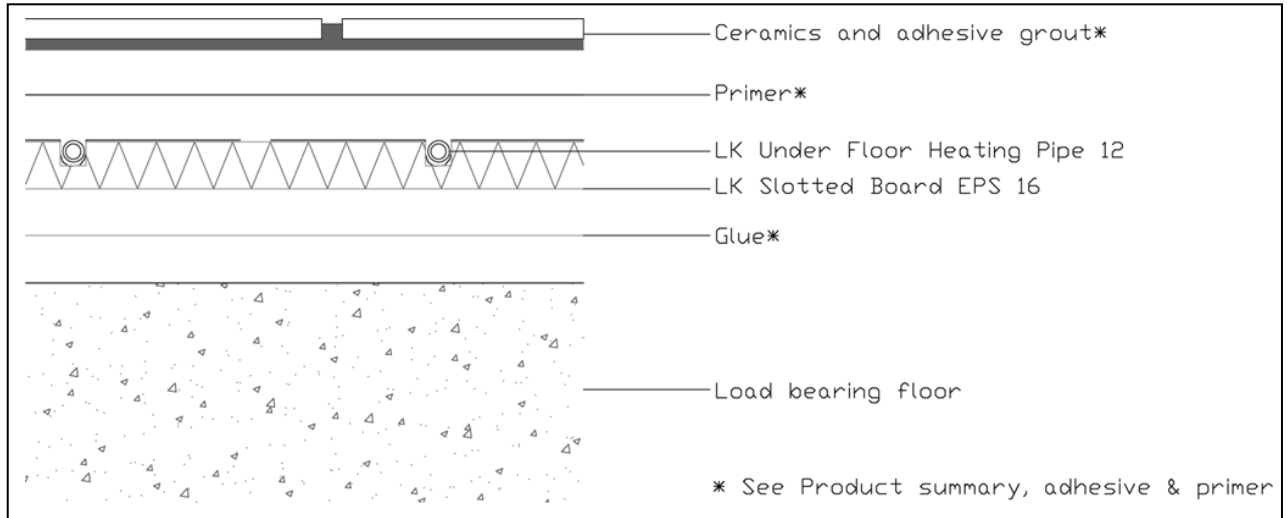

EPS 16 glued on load bearing floor in dry areas. Surface layer ceramics.

Wet areas

The heating plates are glued to the sub-floor. Levelling compound (filler) is applied to form drainage slope (minimum 12 mm thick adjacent to a floor drain). A damp proof membrane or ceramic tiling is fixed to the floor.

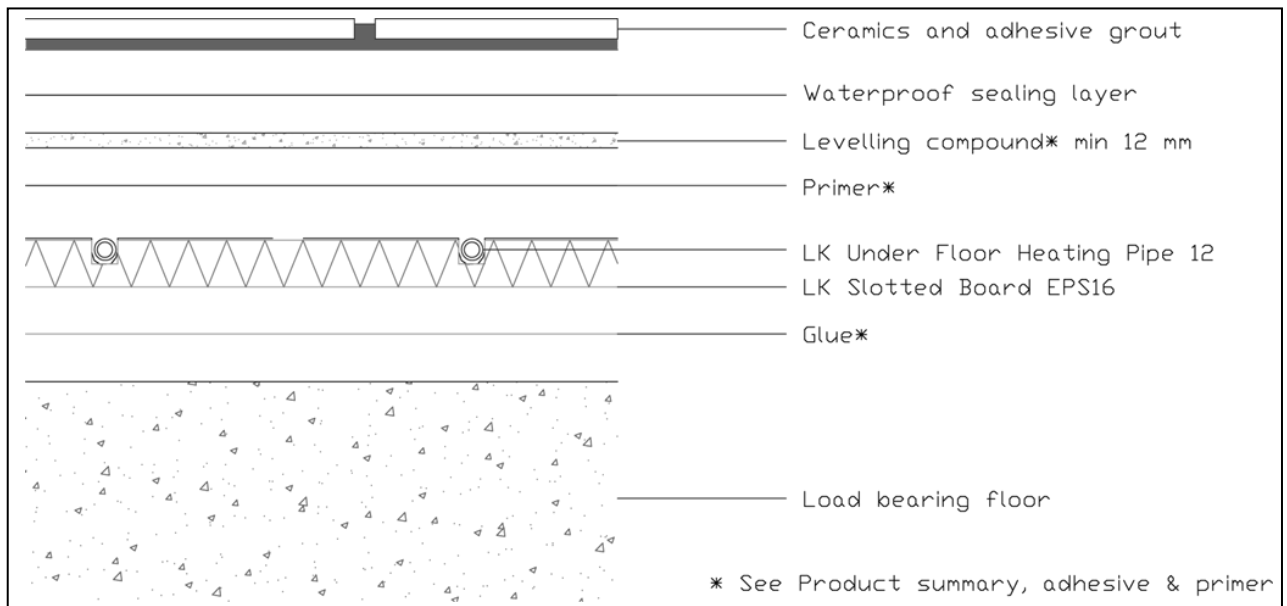

EPS 16 glued on load bearing floor in wet areas. Surface layer ceramics.

Heating Circuit Manifold

The Heating Circuit Manifold should be installed as shown in the design drawing. Please read the instructions enclosed with the manifold.

Laying procedure

Before laying out the plates, inspect the sub-floor to ensure it is level to a maximum curvature ± 3 mm over a distance of 2 metres and ± 1.2 mm over a distance of 0.25 metres. The sub-floor must be vacuumed to remove any dirt or dust.

1. Turning boards

Begin the job by laying out the turning boards. Position the first turning board (which may need shortening) so that the pipe bends coincide with the intended pipe lay-out. Leave a minimum 5 mm for expansion gap alongside walls and other fixed obstacles.

2. Slotted boards

Position the slotted boards so that a minimum 5 mm is left for expansion alongside walls and other fixed obstacles. Cut slotted boards using a jig-saw. Ensure that no metal burrs are left in any pipe slots. Remove all burrs by using a file or sharp blade.

3. Feeding boards

Feeding boards are used for flow and return pipe runs; they are also used where the heating plates do not precisely fit room's dimensions. Leave a minimum 5 mm for expansion alongside walls and other fixed obstacles.

Gluing of under floor heating plates

The plates must be glued with Bostik Multi-Tac or Kiilto Flytfix / Fixbinder as described below. Bostik Multi Tac is suitable for use when looking for the lowest possible elevation. This adhesive should not however, be used on floors where there could be problems with rising damp, for example cellar floors. If there is a risk of rising damp it is best to use Kiilto Flytfix instead. For more information see the details under the respective brands below.

Please note, under floor heating will not resolve potential problems with damp. You need to find the underlying reasons and resolve them first.

Bostik

EPS 16 heating plates can be glued with Bostik Multi Tak to porous surfaces such as concrete, chipboard, plasterboard and cement tiles. There must be no rising damp present.

The surface should be free of oil, grease, paint or other substance that will prevent bonding. The Bostik Multi Tac is applied to the plates. The adhesive is spread/combed out with a notched trowel. Adhesive usage is approx. 2 m²/l. Adjust/centre the turning boards and the slotted boards so that the pipe slots are aligned. Drying time is approx. 12 hours. Drying time is affected by both room temperature and humidity.

When gluing EPS 16 heating plates to a sub floor, it is particularly important that the plates are firmly pressed down into the glue to create the necessary adhesion. For good adhesion, it may be necessary to use sandbags/weights or to screw the plates down. Avoid "unnecessary treading" on the plates before the adhesive has properly set. Adhesive thickness: approx. 1 mm

Bostik Multi Tac is stocked by LK.

EPS 16 heating plates can also be fixed with Kiilto Flytfix to porous surfaces such as concrete, chipboard, plasterboard and cement tiles.

The surface should be free of oil, grease, paint or other substances that will prevent bonding. Adjust/centre the turning boards and the slotted boards so that the pipe slots are aligned. Drying time is approx. 12-18 hours. Drying time is affected by room temperature and humidity.

Mix the Kiilto Flytfix with Kiilto Fixbinder; 5 litres of binder to 20 kg of Flytfix. **(NOTE! No water)**. Spread the adhesive with a putty-knife; work in the adhesive before “combing” it out. Use a comb size of 6-8 mm for the plate. Lay the plate and press firmly down into the adhesive.

When gluing EPS 16 heating plates to a sub floor, it is **particularly** important that the heating plates are firmly pressed down into the glue to create the necessary adhesion. For good adhesion, it may be necessary to use sandbags/weights or to screw the plates to the surface. Avoid “unnecessary treading” on the plates before the glue has properly set. Drying time is approx. 12-18 hours. Drying time is affected by room temperature and humidity.

Adhesive thickness: approx. 3-4 mm

Kiilto Flytfix and Kiilto Fixbinder are stocked by TERRA THERMA.

Priming of under floor heating plates

The topside of the plates must be primed if the intension is to apply tiles directly to the plates. For this use Kiilto Start Primer.

Kiilto Start Primer has outstanding qualities as a primer for expanded polystyrene and aluminium. Ensure the plates are clean; vacuum or alternatively wet/dry vacuum carefully. There must be no grease or oil on the plates and any present must be cleaned off. Apply the Kiilto Start Primer with a brush, including any unused slots. Allow the primer to dry properly (the surface should be totally dry). Kiilto Start Primer is stocked by TERRA THERMA.

Laying the pipe

Plan the pipe lay-out so that flow and return pipes are not crossed.

The pipe lay-out must be done as the Terra Therma drawing. Use the Pipe Decoiler as an aid. Ensure the coil is laid so that outward flow runs along outer walls. Number and name the loops as per the drawing. Before laying out the pipe, check to see that there are no grit or sharps in the slots. Cut the pipe using specialist Pipe Cutters only.

CAUTION: Where several flow and return pipes are connected to manifolds, the floor will have inadequate load bearing capacity. To ensure a level floor, that is strong enough to support furniture and other domestic loads, the insulation boards must be removed from the immediate area around the manifold and the pipes encapsulated in self levelling screed.

4. Laying out the pipe

Press the pipe (by stepping on it) down and into the slotted board. For the installation to be properly complete the pipe must be fully in the slots and under no circumstances must the pipe come into contact with the overlying flooring.

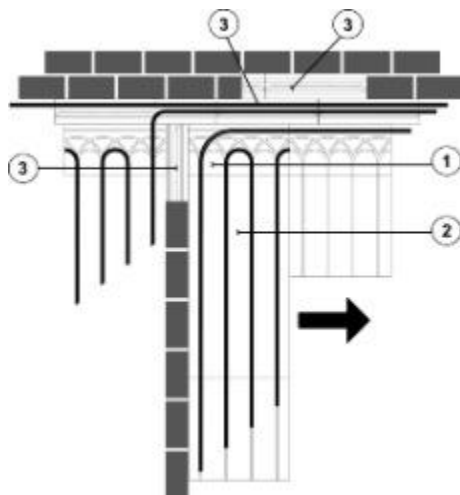

Installing final floor finish

Parquet or laminate floor

The heating plates should be laid “to float”; see the section entitled “Laying out of floor-based heating plates”. The structure is then covered with 2 mm cellfoam. Lay the “floating floor” at right-angles to the direction of the heating loops. Adhere to the instructions provided by the supplier of the wood flooring, as well as national guidelines (in UK – TRADA). Seek advice from Terra Therma if the flooring thickness exceeds 25 mm.

Vinyl, linoleum or carpets

The heating plates should be laid “to float”; see the section entitled “**Laying out of floor-based heating plates**”. The plates are then covered with 2 mm cellfoam (do not use rag board in connection with floor-based heating plates as this can result in squeaking sounds). Next, float 12 mm chipboard (minimum) over the cellfoam. Glue the chipboard panels along the tongue-and-groove edges as set out in the chipboard manufacturer’s instructions. Leave 10 mm for expansion joints alongside walls and other fixed obstacles. Finally, glue or lay the final floor finish over the chipboard flooring as set out in the manufacturer’s instructions.

Wet areas and an alternative solution for dry areas

The heating plates should be glued onto load-bearing floor structures; see the section entitled “Gluing of under floor heating plates”. Ensure that the heating plates are clean; use a vacuum cleaner if necessary. There must be no oil or contaminants on the plates. Apply a coating of Kiilto Start Primer. Also apply the coating to unused pipe slots. Drying time 1-2 hours.

This is followed by application of Kiilto Fiberflex in order to form an adequate drainage slope and to be at least 12 mm thick adjacent to floor drain. Drying/hardening time is 3-4 days (this relatively long

drying time is explained by the fact that the drying takes place via one side only). The next step is to glue on the vinyl. Adhere to the instructions provided by the manufacturer.

Ceramic tiling or natural stone

The heating plates should be glued onto load-bearing floor structures; see the section entitled **“Gluing of under floor heating plates”**. Ensure heating plates are clean; use a vacuum cleaner if necessary. There must be no oil or contaminants on the plates. Apply a coating of Kiilto Start Primer. Also apply the coating to unused pipe slots. Drying time 1-2 hours.

Only start to lay ceramic tiles once the primer is dry. Apply Kiilto Flytfix with a spreader trowel. Adhere to the instructions provided by the manufacturer.

Wet areas

The heating plates should be glued onto load-bearing floor structures; see the section entitled **“Gluing of under floor heating plates”**. See to it that the floor-based heating plates are clean; use a vacuum cleaner if necessary. There must be no oil or contaminants on the plates. Apply a coating of Kiilto Start Primer. Extend the coating application also to unused tubing grooves. Drying time 1-2 hours.

Wet facilities make it necessary to spread a layer of self levelling screed on the heating plate, treated with a primer coating to provide the floor with the necessary slope to the floor drain. The minimum thickness of such a levelling compound coating adjacent to the floor drain is 12 mm; use Kiilto Fiberflex for this purpose. Drying/hardening time is 3-4 days (this relatively long drying time is explained by the fact that the drying takes place via one side only). A sealing layer followed by ceramic tiling can then be applied. Adhere to the instructions provided by the manufacturer.

Product summary, adhesive & primer

The following brands/products have been tested to be used for gluing and priming of our plates.

Never combine different brands so that they have direct contact with each other, e.g. Bostik Primer with Kiilto Flytfix.

LK art. no.	Product name	Usage	Notes	Consumption	Drying time
33520	Kiilto Flytfix, 20 kg	Gluing of under floor heating plates	Mix 5 litres Fixbinder with 20 kg Flytfix	2-3 kg/m ²	12-18 hours
33522	Kiilto Fixbinder, 5 litres	Gluing of under floor heating plates	Mix 5 litres Fixbinder with 20 kg Flytfix	5 l /20 kg Flytfix	Not applicable
33521	Kiilto Start Primer, 3 litres	Priming of under floor heating plates	Only to be used with other Kiilto products	1 l/10m ²	1-2 hours
33520	Kiilto Flytfix, 20 kg	Gluing of ceramics	Mix as per instructions on the	3.5-6 kg/m ²	12-18 hours

			bag		
Not stocked	Kiilto Fiberflex	Screed	Only to be used with Kiilto Start primer	1,6 kg/m ² /mm	3-4 days
Not stocked	Kiilto Rot & Värmegolvspackel (Levelling compound for floors with heating)	Screed	Only to be used with Kiilto Start primer	1,7 kg/m ² /mm	3-5 days

LK art. no.	Product name	Usage	Notes	Consumption	Drying time
33523	Bostik Multi Tac, 10 l	Gluing of under floor heating plates	Not to be used in cases of rising damp	2 m ² /l	12 hours
Not stocked	Bostik Primer/Fuktspärr 6030 (Damp proofing)	Priming (and damp proofing) of under floor heating plates	Only to be used with other Bostik products	1 l / 8 m ²	1-2 hours
Not stocked	Bostik Fix Flyt	Gluing of ceramics to under floor heating plates	Only to be used with Bostik primer 6030	4-8 kg/m ²	10-24 hours
Not stocked	Bostik Fiber Quick	Screed	Only to be used with Bostik primer 6030	1,65 kg/m ² /mm	5-6 days